

PUMP MODEL	MATERIAL
QS4124A	CAST IRON

NOZZLE LIST				
NO	NOZZLE NAME	SIZE	RATING	Q'TY
N1	PUMP SUCTION	6"	ANSI 125# FF	1 EA
N2	PUMP DISCHARGE	6"	ANSI 125# FF	1 EA

ADDITIONAL DIMENSION (mm)							
SEAL PLAN	02/61	23/61	11/61	13/61	52/61	53A/61	53B/61
A	N/A	1050	N/A	N/A	1100	1100	1450
B	N/A	1600	N/A	N/A	1750	1750	2300

PUMP MODEL	MATERIAL
QS4123A	CARBON STEEL
QS4126A	DUCTILE IRON
QS4127A	STAINLESS STEEL

NOZZLE LIST				
NO	NOZZLE NAME	SIZE	RATING	Q'TY
N1	PUMP SUCTION	6"	ANSI 150# FF	1 EA
N2	PUMP DISCHARGE	6"	ANSI 150# FF	1 EA

ADDITIONAL DIMENSION (mm)							
SEAL PLAN	02/61	23/61	11/61	13/61	52/61	53A/61	53B/61
A	N/A	1050	N/A	N/A	1100	1100	1450
B	N/A	1600	N/A	N/A	1750	1750	2300

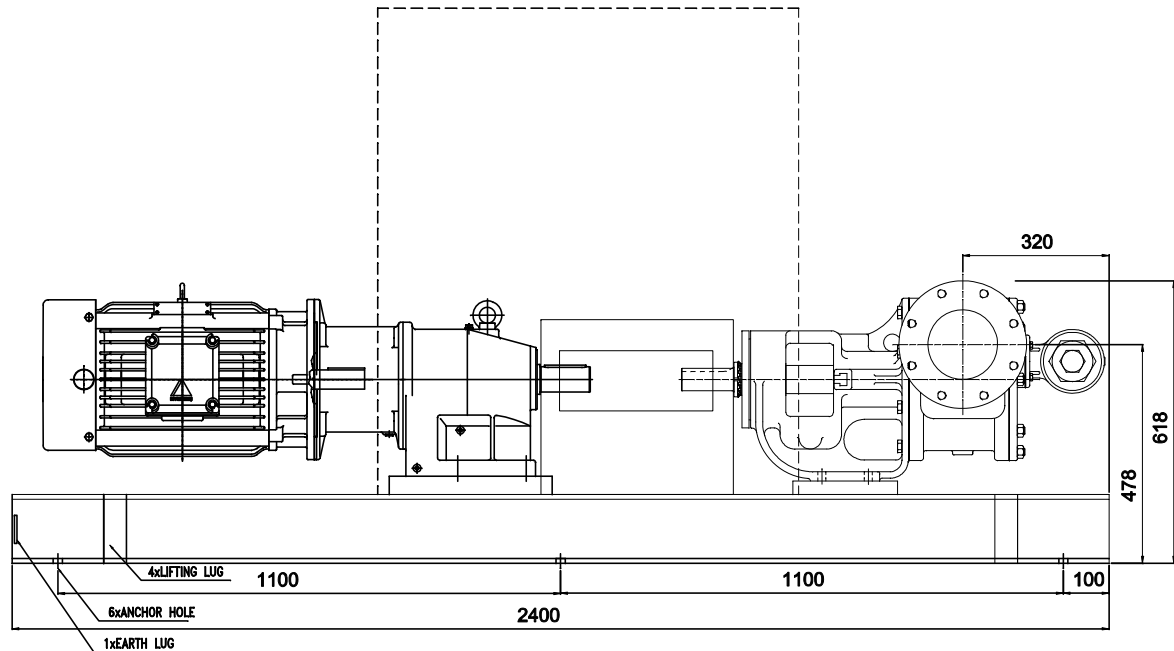

[FRONT VIEW]

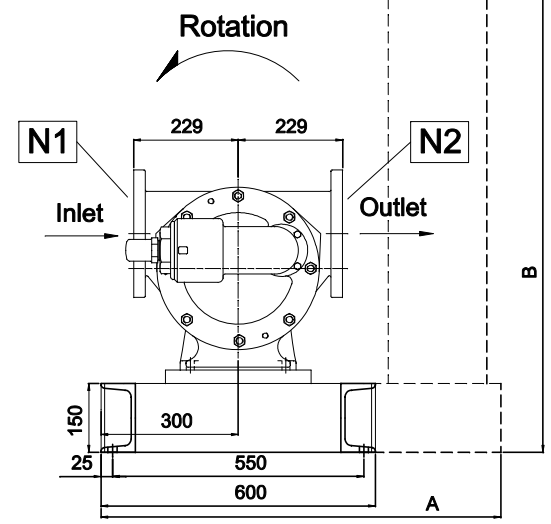

[SIDE VIEW]

REFERENCE ONLY

DRAWING	2017.08.17 J.H.Park	CHECKED	TITLE				
DESIGNED		APPROVED					
POWERKING PUMP Corp.			ANGLE	SCALE	UNIT	DRAWING NO	REV
				NONE	mm	GAD-008	

Assembly Drawing			
VIKING PUMP QS Series			
SCALE	UNIT	DRAWING NO	REV
NONE	mm	GAD-008	

NO	DATE	DESCRIPTION	DWG	DSGN	CHKD	APPD

This drawing is proprietary to POWERKING. No part of this drawing may be reproduced without the permission of POWERKING.